

EXAMENUL DE ATESTARE A CONSILIERILOR ÎN PROPRIETATE INDUSTRIALĂ
- sesiunea mai 2009 -

OBIECTUL : BREVETE DE INVENTIE

PROBA: P2

Domeniul tehnic de specialitate : **ELECTRO și MECANICĂ**

- ▶ Sunteți în conformitate cu prevederile art.39 din Legea 64/91 republicată în 2007, privind brevetele de invenție, **mandatarul autorizat** în fața OSIM al firmei SC TRANS SA cu sediul în Timișoara, înmatriculată la Oficiul Registrului Comerțului sub nr.J12/123/1991 cod unic de înregistrare 1234567. Firma SC TRANS SA produce dispozitive de siguranță și sigilare a containerelor de marfă și consideră că brevetul RO123456 îi încalcă drepturile conferite prin faptul că deține o licență exclusivă pentru producerea și comercializarea a două dispozitive de siguranță și sigilare corespunzător brevetelor US522776 și US3994521, dispozitive ce se află pe piață din anul 1995.
- ▶ Sunteți în poziția de a apăra interesele firmei SC TRANS SA față de deținătorul brevetului RO123456, iar SC TRANS SA vă solicită să depuneți o cerere de revocare a brevetului pentru faptul că îi sunt încălcate drepturile obținute printr-o licență exclusivă pe aceleași produse.
- ▶ Aveți la dispoziție Brevetul RO123456 a cărui hotărâre a fost publicată în data 30.01.2009 în BOPI 1/2009 și cele două brevete americane de mai sus.
- ▶ Vi se cere : Conform art.52 din Legea 64/1991 republicată 2007, să redactați o cerere de revocare a brevetului și să formulați motivele în fapt și temeiurile de drept conform prevederilor Legii 64/1991 republicată în 2007 și Regulamentului de aplicare a legii H.G.457/2008, în ceea ce privește condițiile de brevetabilitate sub aspectul noutății, activității inventive sau al aplicabilității invenției comparativ cu documentele menționate.
- ▶ **OBS:** *Vor fi apreciate corespunzător claritatea și forma de redactare a cererii cu structura sa și analiza elementelor tehnice ce pot demonstra că brevetul RO123456 poate fi revocat.*



d2) BREVET DE INVENȚIE

Hotărârea de acordare a brevetului de invenție poate fi revocată
în termen de 6 luni de la data publicării

(21) Nr cerere: a 2006 12345

(22) Data de depozit: 10.02.2006

(30) Prioritate:

(41) Data publicării cererii:

30.10.2008 BOPI nr. 10/2008

(42) Data publicării hotărârii de acordare a brevetului: 30.01.2009

BOPI nr. 1 2009

(45) Data eliberării și publicării brevetului:

BOPI nr.

(61) Perfecționare la brevet: Nr.

(62) Divizată din cererea:

Nr.

(86) Cerere internațională PCT: Nr.

(87) Publicare internațională: Nr.

(56) Documente din stadiul tehnicii:

FR 2740595

(71) Solicitant: ROMPAC S.A., București

(73) Titular: ROMPAC S.A., București

(72) Inventatori: XXXXXXXXX

(74) Mandatar:

(54) DISPOZITIV DE ÎNCHIDERE ȘI SIGILARE PENTRU ASIGURAREA INTEGRITĂȚII TRANSPORTULUI DE MĂRFURI

(57) **Rezumat:** Invenția se referă la un dispozitiv de închidere și sigilare pentru asigurarea integrității transportului de mărfuri, ca de exemplu, a vagoanelor de cale ferată sau a containerelor. Dispozitivul de închidere și sigilare pentru asigurarea integrității transportului de mărfuri, conform invenției, este alcătuit dintr-un corp metalic (1) care prezintă un prim locaș cilindric (a), în care se fixează un capăt al cablului metalic (2) prin intermediul manșonului de fixare (3) și al pastilei fixe (4), și un al doilea locaș (b) conic, paralel cu primul locaș (a), închis cu ajutorul pastilei de închidere (8), locaș conic, în interiorul căruia este montată o bucă conică (6), tensionată de arcul elicoidal (7), bucă conică (6) prezentând, pe suprafața sa superioară, niște canale (d), în care sunt poziționate radial patru role (5) sau patru bile (5''), care presează celălalt capăt al cablului metalic (2), la introducerea acestuia în cel de-al doilea locaș (b) conic, datorită acțiunii arcului elicoidal (7), realizând blocarea cablului metalic (2) în interiorul dispozitivului.

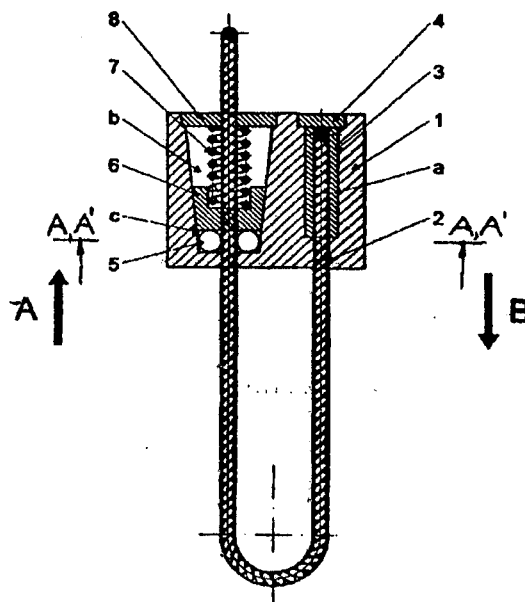

Fig. 1

Revendicări: 3

Figuri: 7

Invenția se referă la un dispozitiv de închidere și sigilare, pentru asigurarea integrității transportului de mărfuri ca, de exemplu, a vagoanelor de cale ferată sau a containerelor, putând fi utilizat însă și la protejarea diferitelor aparate de măsură.

Sunt cunoscute dispozitive de închidere și sigilare alcătuite dintr-o carcasă realizată din două părți sudate și un cablu metalic, ce are unul din capete prevăzut cu niște creștături cu rolul de a bloca capătul cablului metalic atunci când este introdus într-un locaș al carcasei sigiliului, locaș care este prevăzut cu niște clichete care cooperează cu creștăturile realizate pe cablul metalic. (FR 2740595)

Dezavantajele acestei soluții tehnice constă în faptul că prezintă construcție complicată și costisitoare cu o eficiență redusă în ceea ce privește asigurarea unei sigilări corespunzătoare a transportului de mărfuri.

Problema tehnică, pe care o rezolvă invenția de față, constă în realizarea unui dispozitiv care să permită o închidere și sigilare rapidă și sigură a vagoanelor de marfă sau a containerelor, prin intermediul unui cablu metalic, indiferent de diametrul acestuia.

Dispozitivul de închidere și sigilare pentru asigurarea integrității transportului de mărfuri, alcătuit dintr-un corp metalic, ce prezintă un prim locaș cilindric, în care se fixează un capăt al unui cablu metalic prin intermediul manșonului de fixare și al pastilei fixe, și un al doilea locaș conic, paralel cu primul locaș, închis cu ajutorul pastilei de închidere, locaș conic în interiorul căruia este montată o bușcă conică, tensionată de arcul elicoidal, înlătură dezavantajele soluțiilor cunoscute prin aceea că bușca conică prezintă pe suprafața superioară niște canale, în care sunt poziționate niște role, de exemplu patru, care presează celălalt capăt al cablului metalic, la introducerea acestuia în cel de al doilea locaș conic, datorită acțiunii arcului elicoidal, realizând blocarea cablului metalic în interiorul dispozitivului.

Dispozitivul de închidere și sigilare pentru asigurarea integrității transportului de mărfuri prezintă următoarele avantaje:

- montare ușoară;
- sigilare ireversibilă;
- imposibilitatea deschiderii fără distrugerea dispozitivului.

Se dau, în continuare, mai multe exemple de realizare a invenției, în legătură și cu fig. 1... 10, care reprezintă:

-fig.1, secțiune axială prin dispozitiv, conform primului exemplu de realizare;

-fig.2, 3, 4 și 6, vederi și secțiuni ale bușcii conice;

-fig.5, secțiunea e-e din fig 1, reprezentând modul de blocare a cablului metalic prin intermediul rolor;

-fig.7, vedere de sus a bușcii conice și a rolor;

-fig.8, vedere de sus a dispozitivului de închidere și blocare, cu secțiune prin bușca conică

-fig.9, secțiune axială prin dispozitiv, conform celui de-al doilea exemplu de realizare;

-fig. 10, secțiune axială prin dispozitiv, conform celui de al treilea exemplu de realizare.

Dispozitivul de închidere și sigilare, conform primului exemplu de realizare, este alcătuit dintr-un corp metalic **1**, paralelipipedic, în interiorul căruia este realizat un prim locaș cilindric **a**, în care este montat un manșon de fixare **3**, ce are rolul de a reține unul din capetele cablului metalic **2**, care are rolul de închidere a containerelor sau incintelor.

Reținerea manșonului de fixare **3** și respectiv a capătului cablului metalic **2**, în interiorul corpului metalic **1**, se realizează prin intermediul unei pastile fixe **4**, montată pe latura inferioară a corpului metalic **1**.

În interiorul corpului metalic **1**, paralel cu locașul cilindric **a**, este realizat un al doilea locaș **b**, conic, în interiorul căruia este montată o bușcă conică **6**, ce prezintă un orificiu longitudinal **c**, pentru introducerea celuiilalt capăt al cablului metalic **2**, precum și niște canale **d**, în care sunt poziționate niște role **5**, de preferință, în număr de patru.

Numărul rolor **5** depinde, în principal, de diametrul cablului metalic **2**, precum și de numărul toroanelor care îl compun.

În practică, pentru beneficiarii care au nevoie de sigilarea transporturilor de mărfuri, cu un cablu metalic, de diametru mai mare, de exemplu 6-8mm, este necesară utilizarea unui număr de patru role, astfel încât fiecare rolă să prindă pe unul din toroanele din care este alcătuit cablul metalic.

Pentru diametre mai mici, ale cablului metalic **2**, de exemplu 1-1,5mm, dispozitivul poate fi prevăzut cu un număr mai mic de role, de exemplu, două sau trei, dispuse în canalele **d** realizate pe bucușă conică **6**, întrucât și numărul toroanelor care alcătuiesc cablul metalic de aceste diametre este mai mic.

Tot în interiorul locașului conic **b**, sub bucușă conică **6**, este poziționat un arc elicoidal **7**, care este fixat și tensionat în locașul conic **b**, prin intermediul unei pastile de închidere **8**, montată ca și pastila fixă **4**, pe latura inferioară a corpului metalic **1**, pastila de închidere **8**, prezentând un orificiu **e** pentru a permite trecerea cablului metalic **2**.

Închiderea dispozitivului se realizează prin introducerea capătului cablului metalic **2** în interiorul orificiului longitudinal **c** al bucușei conice **6**, în sensul săgeții **A**.

Modul de dispunere a bucușei conice **6**, a rolor **5** și respectiv, a arcului elicoidal **7**, în interiorul locașului conic **b**, precum și dimensiunile constructive ale arcului elicoidal **7**, permit introducerea ușoară a capătului cablului metalic **2** în vederea închiderii dispozitivului.

În momentul în care cablul metalic **2** nu mai este împins în interiorul corpului metalic **1** al dispozitivului, arcul elicoidal **7** se destinde și face ca bucușă conică **6** să se deplaseze către partea superioară a locașului conic **b**, astfel încât rolele **5** să preseze cablul metalic **2** și să nu mai permită deplasarea cablului metalic **2**, în sensul deschiderii dispozitivului, conform săgeții **B**.

Dispozitivul de închidere și sigilare, conform celui de-al doilea exemplu de realizare, prezintă în interiorul corpului metalic **1** un locaș longitudinal **c'**, paralel cu locașul **a**, și în care este introdus capătul liber al cablului metalic **2**, închiderea dispozitivului realizându-se prin intermediul unei bile **10** care este presată pe cablul metalic **2** cu ajutorul unui șurub de fixare **9**, montat perpendicular pe cablul metalic **2**, într-un locaș filetat **f**.

Șurubul de fixare **9** împiedică deschiderea sau desigilarea dispozitivului, prin faptul că după înfiletare, capul acestuia este retezat în planul corpului metalic **1**.

De asemenea, corelarea diametrelor bilei **10** și respectiv a cablului metalic **2** permite ca, la strângerea șurubului de fixare **9**, bila să nu afecteze rezistența cablului metalic **2**, ci doar să lase o singură amprentă de identificare, în cazul în care se constată deschiderea frauduloasă a containerului sigilat prin intermediul dispozitivului.

Într-un alt exemplu de realizare, ambele capete ale cablului metalic **2** sunt fixate în niște canale longitudinale paralele **a'**, **c'** din interiorul corpului metalic **1**, cu ajutorul bilelor **10** care sunt presate pe cablul metalic **2** prin intermediul șuruburilor de fixare **9**.

Revendicări

1. Dispozitiv de închidere și sigilare, pentru asigurarea integrității transportului de mărfuri, caracterizat prin aceea că este alcătuit dintr-un corp metalic (1) care prezintă un prim locaș cilindric (a), în care se fixează un capăt al cablului metalic (2), prin intermediul manșonului de fixare (3) și al pastilei fixe (4) și un al doilea locaș (b) conic, paralel cu primul locaș (a), închis cu ajutorul pastilei de închidere (8), locaș (b) conic în interiorul căruia este montată bușca conică (6) tensionată de arcul elicoidal (7), ce prezintă, pe suprafața sa superioară, niște canale (d) în care sunt poziționate niște role (5), de exemplu, patru, care presează celălalt capăt al cablului metalic (2), la introducerea acestuia în cel de-al doilea locaș (b) conic, datorită acțiunii arcului elicoidal (7), realizând blocarea cablului metalic (2) în interiorul dispozitivului.

2. Dispozitiv de închidere și sigilare, conform revendicării 1, caracterizat prin aceea că, în interiorul corpului metalic (1), perpendicular pe locașul cilindric (a), este prevăzut un șurub de fixare (9), care presează în capătul dinspre interior o bilă (10) cu ajutorul căreia se realizează blocarea cablului metalic (2), într-un canal longitudinal (c').

3. Dispozitiv de închidere și sigilare, conform revendicării 2, caracterizat prin aceea că atât capătul fix, cât și capătul liber al cablului metalic (2) sunt fixate în două locașuri longitudinale (a', c') paralele, din interiorul corpului metalic (1), iar perpendicular pe acestea, sunt prevăzute două șuruburi de fixare (9), care presează în capătul dinspre interior câte o bilă (10) cu ajutorul cărora se realizează blocarea cablului metalic (2).

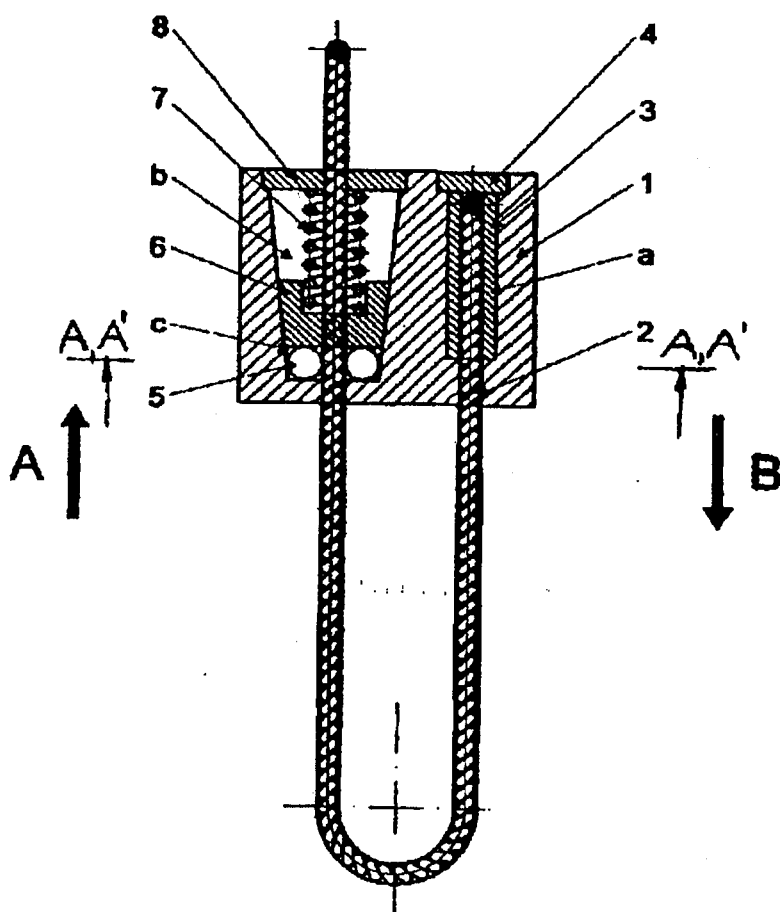

Fig. 1

A - A

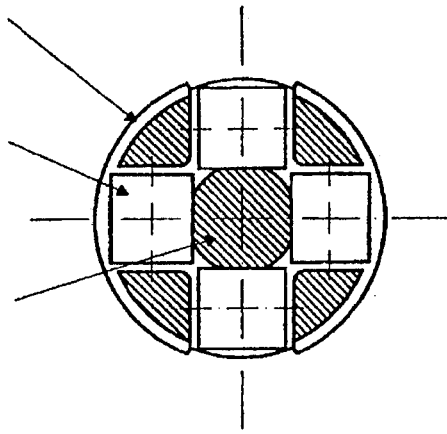

Fig. 2

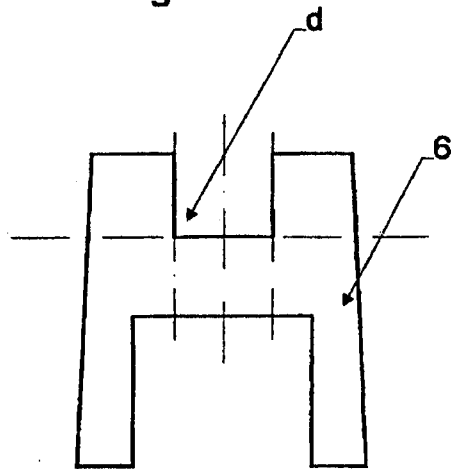

Fig. 4

A' - A'

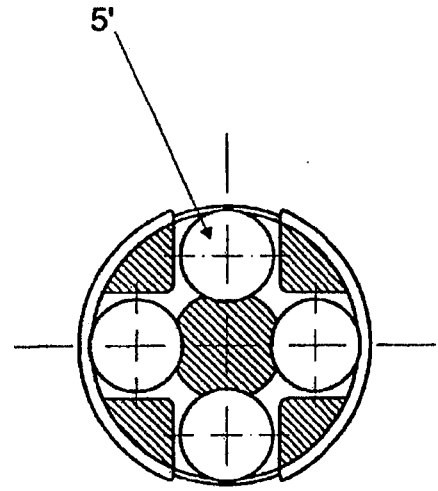

Fig. 3

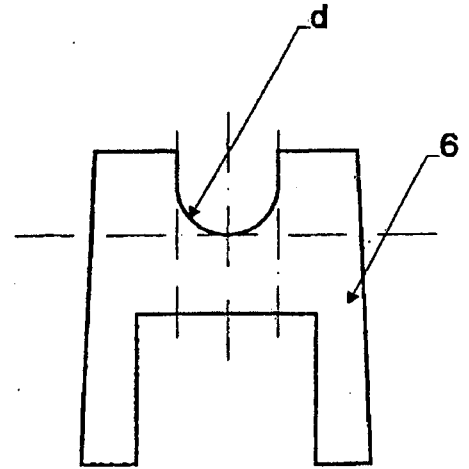

Fig. 5

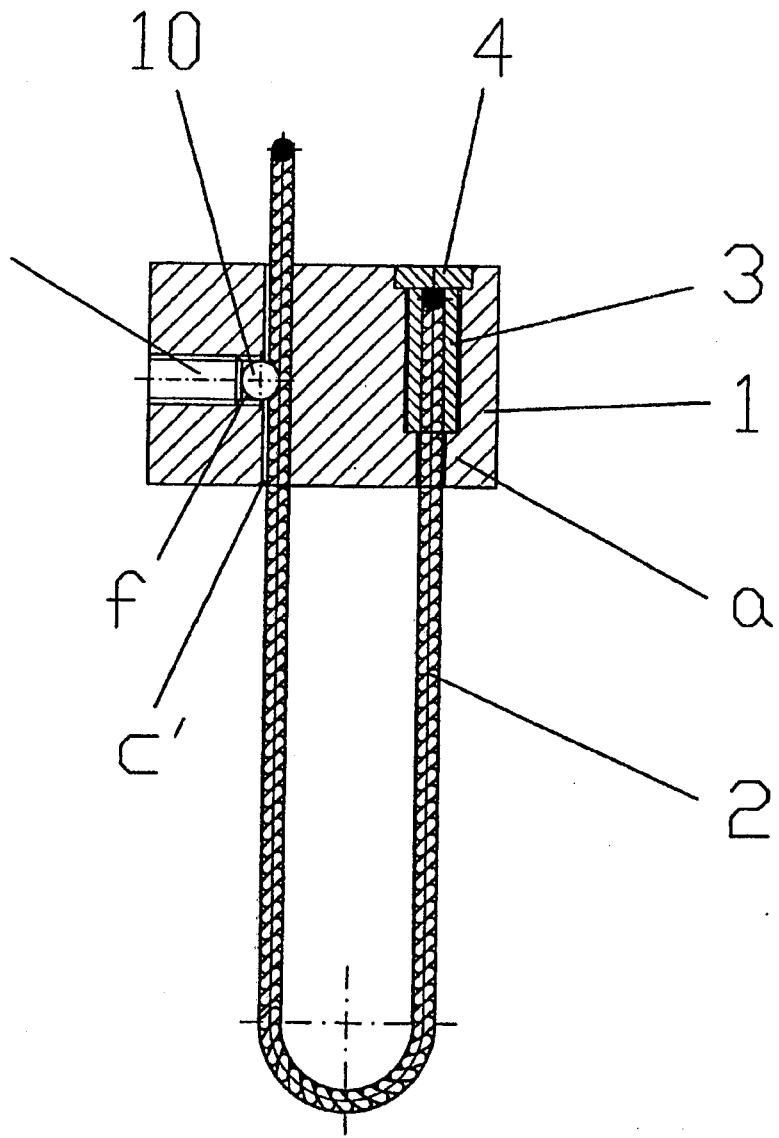

Fig.6

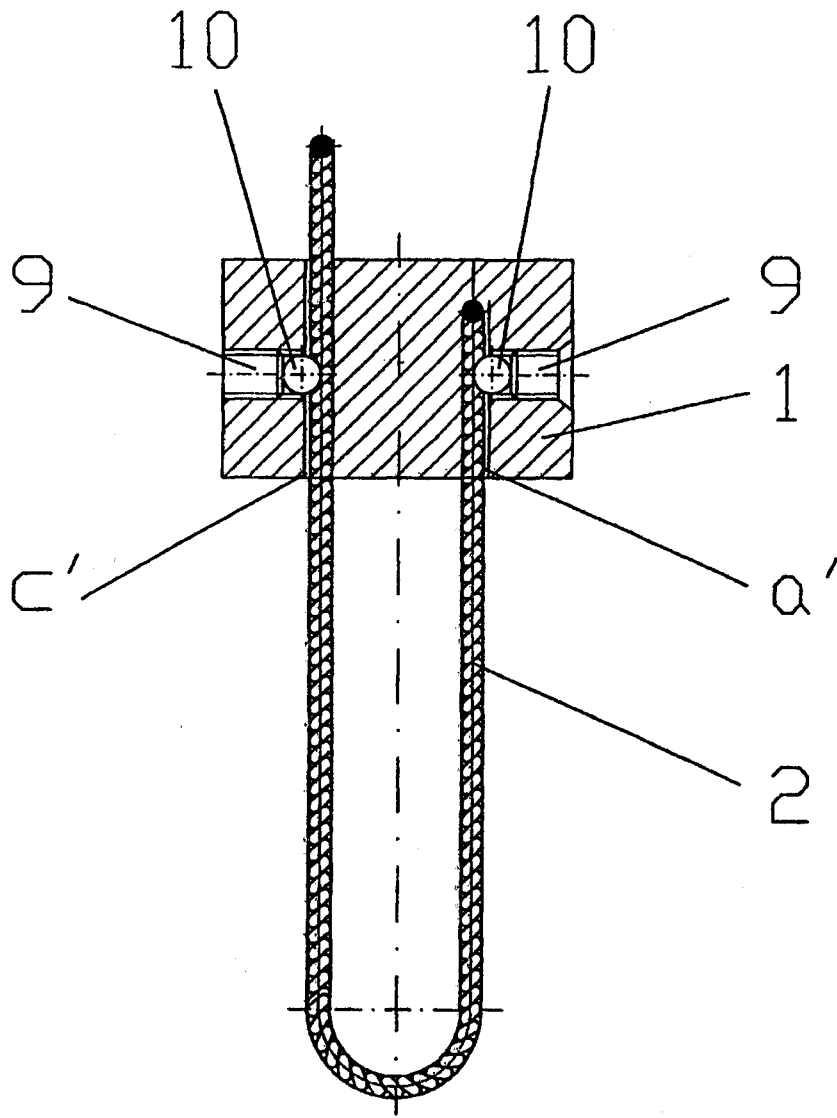

Fig.7

- [54] PORTABLE CABLE LOCK WITH BALL DETENTS
- [75] Inventor: James Van Gompel, Fremont, Ind.
- [73] Assignee: Brammall, Inc., Angola, Ind.
- [22] Filed: Sept. 3, 1975
- [21] Appl. No.: 610,062

Primary Examiner—Richard E. Moore
 Attorney, Agent, or Firm—Hill, Gross, Simpson, Van Santen, Steadman, Chiara & Simpson

- [52] U.S. Cl. 292/319; 292/252; 24/136 A
- [51] Int. Cl.² B65D 55/06
- [58] Field of Search 292/252, 323, 319, 327, 292/318; 24/136 A

[57] ABSTRACT

A locking means for providing a seal comprising a locking shell formed with a central passageway which is internally tapered with an opening that changes from conical to triangular in shape and which carries spring loaded ball bearings and a retainer such that a cable can be inserted through the central opening in a first direction, thus, depressing the spring and allowing the balls to relieve pressure on the cable in said first direction but which provides substantial and locking pressure on the cable when the cable is placed under tension in the opposite direction. The cable may also be attached to a second fixed member such that a seal may be made by placing the locking case and the fixed member on the same cable.

- [56] References Cited
 UNITED STATES PATENTS
- | | | | |
|-----------|--------|--------------|-----------|
| 848,879 | 4/1907 | Brown..... | 292/318 |
| 1,577,678 | 3/1926 | Behrman..... | 292/319 X |
| 2,469,592 | 5/1949 | Byer..... | 292/327 X |

8 Claims, 9 Drawing Figures

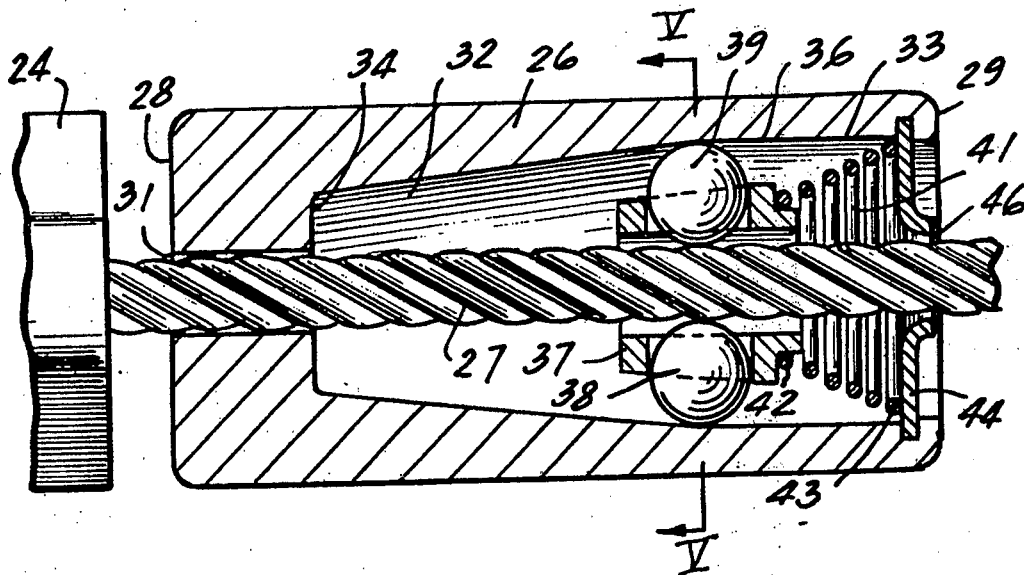

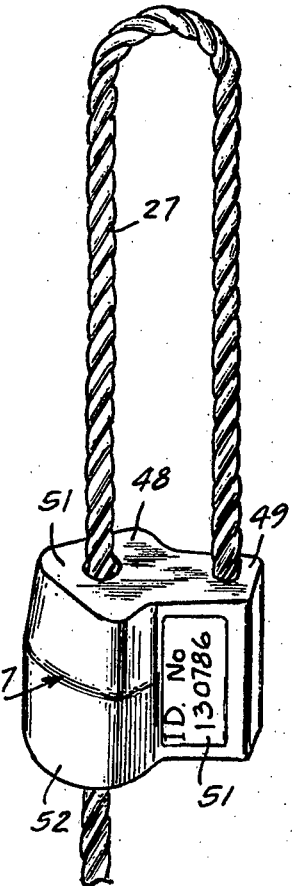
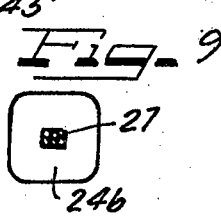
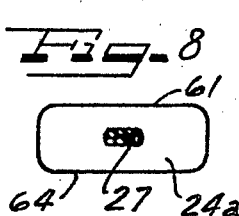
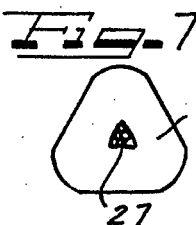
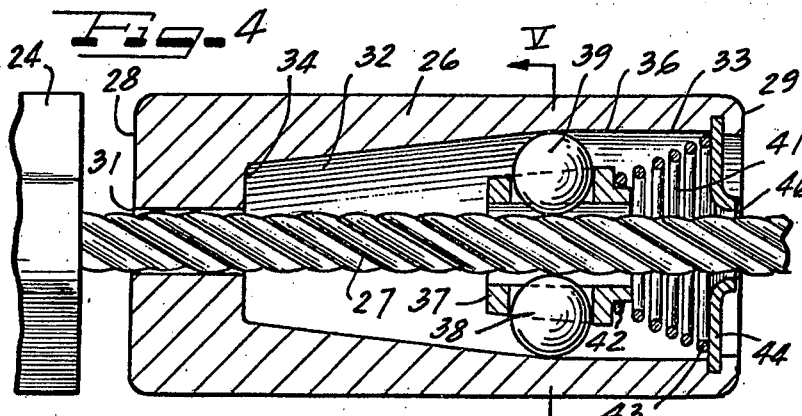
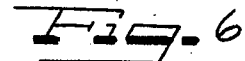
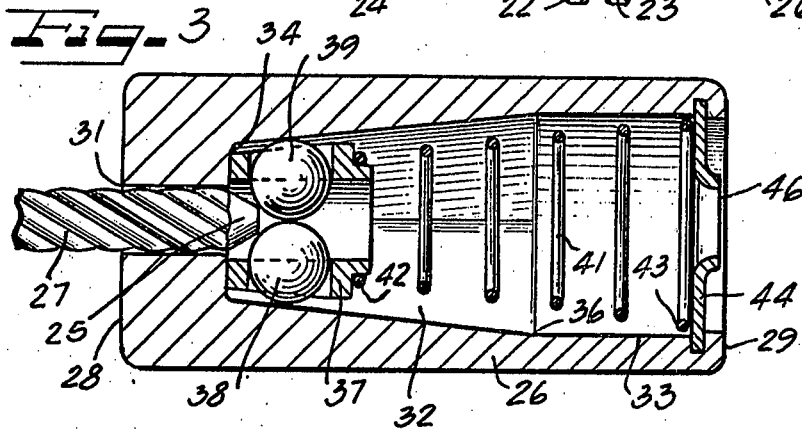
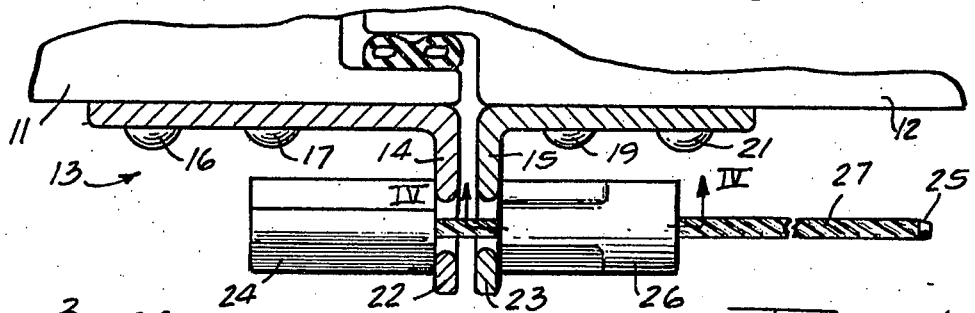
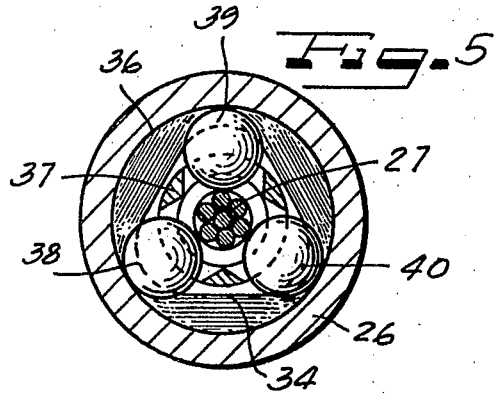
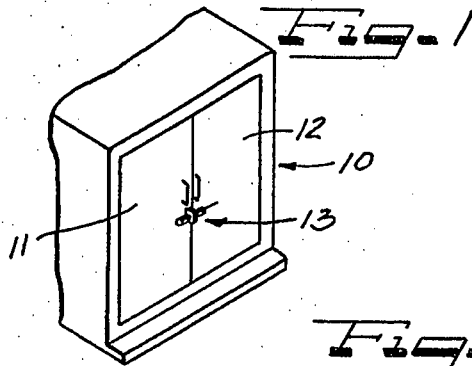

PORTABLE CABLE LOCK WITH BALL DETENTS

BACKGROUND OF THE INVENTION

1. Field of the Invention

This invention relates in general to locking means and in particular to locking means utilizing a line or cable.

2. Description of the Prior Art

My prior art U.S. Pat. No. 3,770,307 discloses a cable lock and seal device for a flexible cable and an enclosure fixed secured to one end of the cable and with a passageway to receive the end of the cable there-through and having a wedge element and disc-shaped jam element for locking the cable so that it can move freely in one direction but it is restricted from moving in the other direction.

SUMMARY OF THE INVENTION

The present invention relates to a locking means which is positive and which is used to represent what is commonly known as the "bolt" in conventional locks wherein in order to gain access into the locked parcel the bolt would have to be destroyed and also a lock is to be created that could not be "picked". The present invention comprises a locking shell through which a cable can be inserted and which has an internal tapered surface which goes from a round to triangular shape and which carries therein a cluster of balls mounted in a retainer which is spring tensioned in a first direction within the shell retainer. A cable can be inserted into the shell retainer so as to separate the balls and depress the spring thus allowing the balls to ride up the conical and triangular surface and separate allowing the cable to pass between the cluster of balls and out the other end of the shell retainer. When tension is applied to the cable to move it in the opposite direction out of the shell retainer, such tension causes the balls to move in the same direction as the tension on the cable, thus, forcing extreme pressure on the cable due to the conical and triangular shape of the internal surface of the shell retainer, thus, clamping and preventing the cable from being moved in the second direction relative to the shell. A second piece of the locking member comprises a body of material which is permanently crimped to the cable such that the locking case and the fixed member form a secure locking means.

The locking case can also be integrally formed with the fixed member such that the cable can be doubled back through the locking case.

Further objects, features and advantages of the invention will be readily apparent from the following description of certain preferred embodiments thereof taken in conjunction with the accompanying drawings although variations and modifications may be effected without departing from the spirit and scope of the novel concepts of the disclosure and in which

BRIEF DESCRIPTION OF THE DRAWINGS

FIG. 1 is a perspective view of a locking device of the invention mounted on a pair of doors;

FIG. 2 is a side elevational view of the invention;

FIG. 3 is a sectional view taken on line 4—4 in FIG. 2;

FIG. 4 is a sectional view taken on line 4—4 in FIG. 2;

FIG. 5 is a sectional view taken on line 5—5 in FIG. 4;

FIG. 6 illustrates a modification of the invention wherein the locking case and fixed member are integrally formed;

FIG. 7 is an end view taken from FIG. 2 of the fixed device;

FIG. 8 is an end view of a modified fixed member, and

FIG. 9 is an end view of a further modified fixed member.

DESCRIPTION OF THE PREFERRED EMBODIMENTS

FIG. 1 illustrates the rear end of a truck 10 which has doors 11 and 12 which are secured by the locking device 13 of the invention. As shown in FIG. 2, the door 11 has an L-shaped member 14 attached thereto by screws or bolts 16 and 17 and the door 12 has an L-shaped member 15 attached thereto by bolts or nuts 19 and 21. The outer extending legs 22 and 23 are formed with openings through which the locking cable 27 of the invention extends. One end of the cable 27 is permanently attached to the fixed retaining means 24 and the free end of the cable is passed through the openings in portions 14 and 15 and the locking case 26 is passed over the end 25 of the cable 27 until it is against the portion 23. Since the locking case 26 can be freely moved in one direction relative to the cable which is to the left relative to FIG. 2 and which cannot be moved to the right relative to FIG. 2 due to its locking action a seal with a high degree of integrity is provided.

As shown in FIGS. 7, 8 and 9, the fixed member 24 is formed by crimping a block of aluminum having a central opening to the cable 27. The present member 24 comprises a substantial improvement over prior art members which are crimped onto a cable because with prior art devices the crimping is accomplished with crimping jaws that are circular or nearly circular in which case there is no real distortion of the cables original shape and the cable remains round. I have discovered that by using crimping shapes such as triangular, rectangular or square that substantially improved bonding between the cable 27 and the members 24 is accomplished. FIG. 7, for example, illustrates a fixed member 24 crimped in a triangular shape so that the central opening crimps the cable 27 into a triangular shape thus distorting the round shape of the cable causing each strand of the cable to have to find its own way out of the crimped object instead of following the path of the strand preceeding it. I have found that where a round crimp such as used in the prior art is utilized, that the path of each strand follows a definite spiral wherein it is stripped from the holding member whereas the path of each strand with a triangular, rectangular or square crimp such as illustrated in FIGS. 7, 8 and 9, respectively, are indefinite and do not follow any general pattern.

I have also discovered that starting with a round block of material with a central round opening which is crimped into a triangular shape such as shown in FIG. 7 that the center opening of the member 24 will be even more triangular than the external surface of the member 24.

I have also discovered that the bulky mass of the member 24 when made of aluminum, for example, is unaffected by the application of a burning flare or a propane torch due to the bulky cross-sectional area

whereas with prior art seals having less bulk seals have been destroyed.

The generally flat-shape of the form shown in FIG. 8 utilizing a rectangular crimp provides two flat surfaces 61 and 64 upon which the seal number and other necessary or desirable imprinting can be placed.

The locking shell of the invention 26 is illustrated in sectional view in FIGS. 3 and 4 includes a generally cylindrical shell member 26 formed with a central opening 31 at a first end which opens into a larger opening 33 which extends to the end 29. The opening 31 at the end 28 of the shell is large enough to allow the end 25 of the cable to pass therethrough and a retainer member 44 formed with a central opening 46 is secured in the body member 26 adjacent the end 29 as shown. The internal space of the locking shell is formed with a cylindrical opening 33 and a tapered opening 32. The cylindrical opening 33 is adjacent the end 29 and the end retainer 44 and joins to a conical portion at a point 36 which passes into the tapered opening 32 to the end 34. As shown in FIG. 5, the conical tapered opening extends from point 36 and generally by transition goes into a triangular shaped opening before point 34.

A cluster of balls 38, 39 and 40 are held by a ball retainer 37 which has a central opening through which the balls extend and through which the cable 27 can extend. The retainer 37 is also formed with openings such that the balls 39 can engage the inner surface of the locking shell as shown in FIGS. 3, 4 and 5.

A coil spring 41 has a first end 43 which bears against the end plate 44 and a second end 42 which bears against the ball retainer 37 so as to bias it to the left relative to FIGS. 3 and 4.

The diameter of the cylindrical portion 33 of the internal opening of the locking shell is chosen such that when the cable 27 is inserted through the locking shell the balls will allow relatively free passage of the cable to the right as shown in FIG. 4. The tapered portion between points 36 and 34 of the internal opening 32 is such that upon the application of tension to the cable 27 to move the cable to the left relative to the shell 26 the balls 38, 39 and 40 will be cammed by the surface between the points 34 and 36 toward the center line of the cable 27 thus locking the cable so that it cannot be withdrawn by moving it to the left relative to FIG. 4.

In operation, the end 25 of the cable 27 is inserted through the opening 31 until it bears against the balls, 38, 39 and 40 and is further inserted into the locking shell and pushes the balls and the ball retainer 37 to the right relative to FIG. 3, thus, allowing the balls 38, 39 and 40 to move away from the cable until when the ball reach the point 36 illustrated in FIG. 4, the cable 27 can freely pass through the space between the balls and out the opening 46 of the retaining wall 44. As long as the cable is moved to the right relative to FIG. 4, the balls 38, 39 and 40 and the retainer 37 will remain in the position illustrated in FIG. 4, but any attempt to move the cable 27 to the left relative to FIG. 4 will immediately cause the balls 38, 39 and 40 to move on the internal conical and triangular shape surface between points 36 and 34 thus moving the balls together and applying pressure on the cable 27 so as to lock it for movement to the left relative to FIG. 4.

The shell 26 can be formed by deep drawing a sheet of flat stock or could be produced on a screw machine or a lathe from bar stock. It could also be cast or injection molded. The locking shell 26 and the fixed member 24 could be made of brass, aluminum, copper or

steel. Cinkered or powdered metal or nylon, delron or other plastics could also be used.

This lock can be applied in many applications whenever cinching, locking, suspending, connecting or taking up of a slack line is required.

Although three balls are illustrated in particular locking shells, it is to be realized that any number of balls such as 2, 3 or more could be used. The diameter of the balls would be chosen so as to be compatible with the size of the cable.

In one particular example utilizing cable having a 3/16 inch diameter, 1/4 inch balls were used. I have found that three balls provides the best necking down of the cable effect.

In a particular model constructed I have found that a resistance for approximately 5 pounds pressure is required to insert the cable into the locking shell and this resistance is the result of the compression of the spring 41 coupled with the friction of the balls 38, 39 and 40 and the ball retainer 37 as well as the friction between the balls and the inside wall of the shell 26.

By pushing on the cable 27, the balls are forced to roll upwardly relative to FIG. 3 toward the larger end of the cone and outwardly from the axis of the cone until the cluster of balls is spread far enough to allow the cable to pass through the cluster. Further pushing of the cable 27 allows it to move out the shell retainer 26 until the fixed member 27 and the shell member 26 are both touching the hasp members 14 and 15 thus leaving no exposed cable and locking procedure has been completed.

I have discovered that when an attempt is made to remove the cable by pulling and twisting to the left relative to FIGS. 2 and 4 that by reshaping the internal surface 32 so that it goes from a cone at point 36 to a triangular shape at point 34 prevents the balls from rolling around the inner surface of the triangular shaped portion toward the end 34 which substantially prevents the cable from being twisted from the lock. This triangular portion adjacent the end 34 can be seen in the sectional view 5 wherein the conical portion 36 gradually goes into a triangular shape portion at 34.

A modification of the invention is illustrated in FIG. 6 wherein the retainer and shell member are integrally formed in a single unit 47. A portion 49 is generally square-shaped in cross-section as illustrated in FIG. 9 and is crimped to the cable 27. An enlarged portion 48 is generally triangular shaped and is formed with a conical and triangular shaped opening and is fairly similar to the shell member 26 illustrated in FIG. 2 with the exception that it has been permanently bonded to the member 49 or may be integrally formed with the member 49. A flat portion 51 allows the seal identification to be attached and in use the free end of the cable is passed through the locking means which might be a hasp and then into the end 51 of the portion 48 and out the end 52. The balls within the shell member 48 prevent the cable 27 from being drawn upward relative to FIG. 6 but it can be freely drawn downwardly until the desired length of the cable 27 extends between the surfaces 49 and 51.

It is seen that this invention provides new and novel locking means and although it has been described with respect to preferred embodiments it is not to be so limited as changes and modifications may be made which are within the full intended scope of the invention as defined by the appended claims.

I claim as my invention:

5

- 1. A locking means comprising, a line, a fixed member attached to said line, a locking shell formed with a central opening and said line receivable therethrough, said locking shell central opening formed with a first portion large enough to receive said line there-through and an enlarged tapered second portion, a ball retainer, a plurality of balls held by said ball retainer in said second portion of said central opening and engage-able with said line to allow it to pass freely through said locking shell in a first direction and to lock said line to prevent it from moving through said locking shell in a second direction opposite to said first direction, spring biasing means engageable with said ball re-tainer to bias it in the second direction, wherein said enlarged tapered second portion of said central opening is conical in shape at its largest dimension and makes a transition until it has walls which meet at angles at its smallest dimension, and wherein said walls meet at acute angles.
- 2. A locking means according to claim 1 wherein there are three balls held by said ball retainer.
- 3. A locking means according to claim 1 including an end portion of said locking shell formed with an open-ing large enough for said line to freely pass there-through and said spring biasing means comprising a coil spring mounted between said end portion and said ball retainer.

6

- 4. A locking means according to claim 1 wherein said fixed member and said locking shell are attached to-gether side by side to form an integral unit.
- 5. A locking means according to claim 1 wherein said line is a metal stranded cable.
- 6. A locking means according to claim 5 wherein said fixed member has a central opening which is attached to said line by crimping it into a non-circular configura-tion.
- 7. A locking means comprising, a line, a fixed member attached to said line, a locking shell formed with a central opening and said line receivable therethrough, said locking shell central opening formed with a first portion large enough to receive said line there-through and an enlarged tapered second portion, a ball retainer, a plurality of balls held by said ball retainer in said second portion of said central opening and engage-able with said line to allow it to pass freely through said locking shell in a first direction and to lock said line to prevent it from moving through said locking shell in a second directon opposite to said first direction, spring biasing means engageable with said ball re-tainer to bias it in the second direction, wherein said enlarged tapered second portion of said central opening is conical in shape at its largest dimension and makes a transition until it has walls which meet at angles at its smallest dimension, and wherein said walls meet at right angles.
- 8. A locking means according to claim 7 wherein there are four balls held by said ball retainer.

* * * * *

35

40

45

50

55

60

65

UNITED STATES PATENT AND TRADEMARK OFFICE
CERTIFICATE OF CORRECTION

PATENT NO. : 3,994,521

DATED : November 30, 1976

INVENTOR(S) : James Van Gompel

It is certified that error appears in the above-identified patent and that said Letters Patent are hereby corrected as shown below:

Column 1, line 26, "preset" should be --present--.

Column 3, line 51, "ball" should be --balls--.

Column 5, line 31, "engough" should be --enough--.

Column 6, line 23, "directon" should be --direction--.

Signed and Sealed this

Fifth Day of April 1977

[SEAL]

Attest:

RUTH C. MASON
Attesting Officer

C. MARSHALL DANN
Commissioner of Patents and Trademarks



US005222776A

United States Patent [19]

[11] Patent Number: **5,222,776**

Georgopoulos et al.

[45] Date of Patent: **Jun. 29, 1993**

- [54] SECURITY SEAL AND LOCK
- [75] Inventors: George Georgopoulos, Pine Brook;
Richard C. Dreisbach, North
Arlington, both of N.J.
- [73] Assignee: E. J. Brooks Company, Newark, N.J.
- [21] Appl. No.: 973,788
- [22] Filed: Nov. 9, 1992
- [51] Int. Cl.⁵ B65D 33/34
- [52] U.S. Cl. 292/323; 292/307 R;
292/252
- [58] Field of Search 24/115 G, 115 L, 136 A,
24/136 L; 292/252, 307 R, 315, 319, 321, 325,
326, 327, 323, 307 B, 318

- 4,280,726 7/1981 McCoag 292/318 X
- 4,640,538 2/1987 Brammall 292/323
- 4,747,631 5/1988 Loynes et al. 292/307 R

Primary Examiner—Richard E. Moore
Attorney, Agent, or Firm—John G. Gilfillan, III

[57] ABSTRACT

A seal and lock includes a flexible metal cable held permanently at one end in a housing, the other end being insertable through the housing and is locked therein by a spring-biased ball which wedges against the cable upon an attempt to pull the cable from the housing. A second ball is located between the spring and the first-mentioned ball, and wedges against the cable to further prevent removal thereof and to prevent twisting of the cable as a way of removing the cable from the housing. The second ball is of sufficiently soft material so that the cable when pulled digs into the second ball to increase the jamming force against the cable.

[56] References Cited U.S. PATENT DOCUMENTS

- 918.570 4/1909 Mather 292/318
- 3,994.521 11/1976 Van Gompel 292/252 X
- 4,049.303 9/1977 Irwin et al. 292/307 R

12 Claims, 2 Drawing Sheets

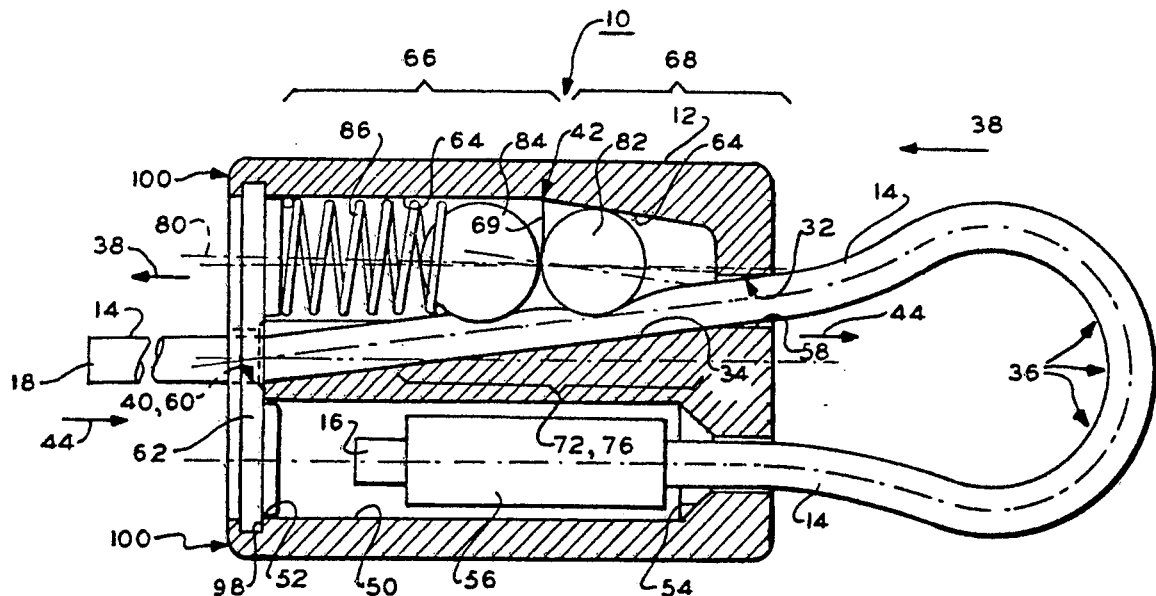

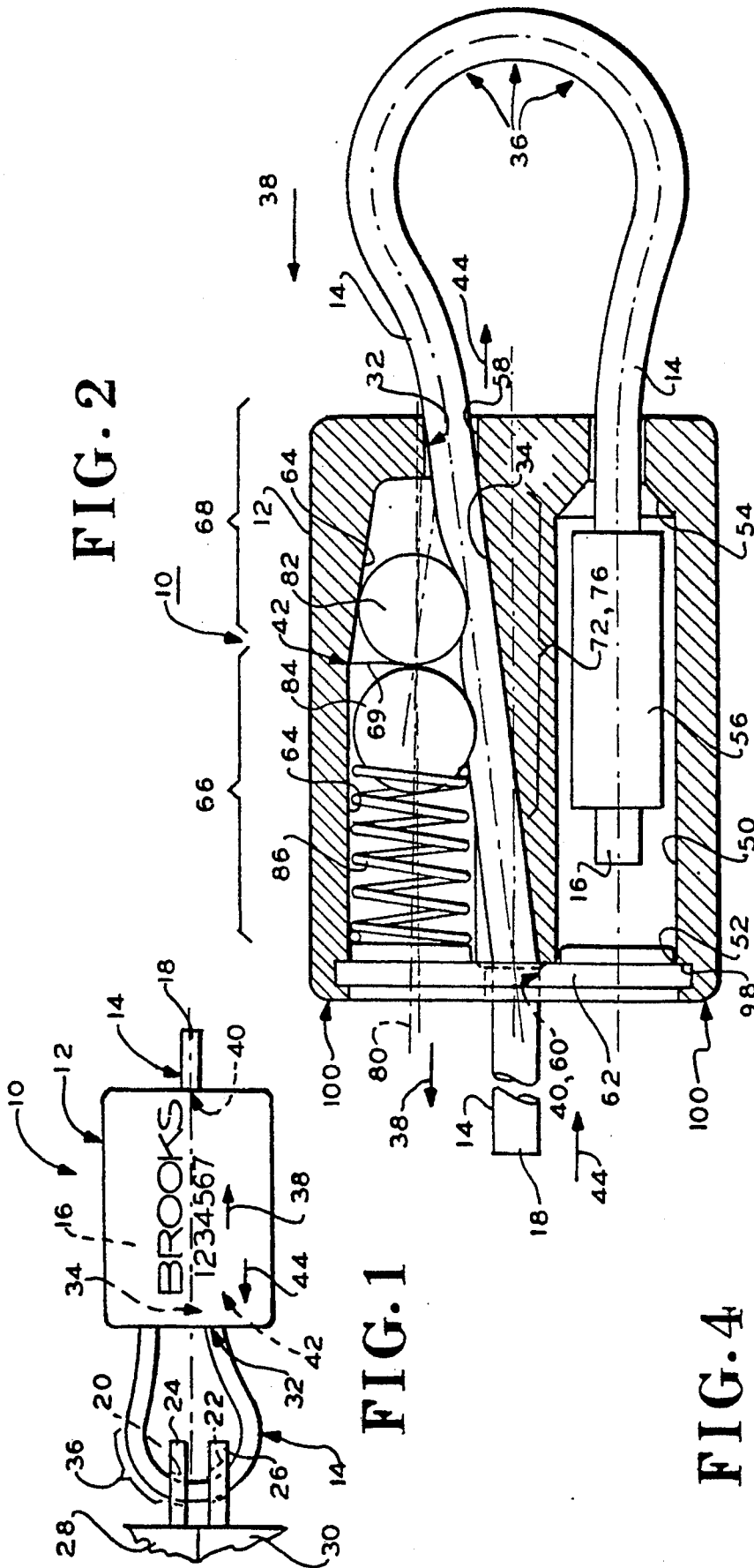

FIG. 1

FIG. 2

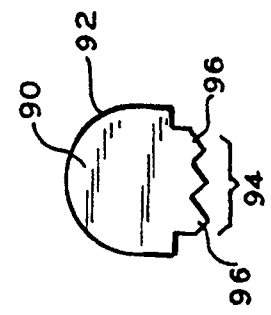

FIG. 4

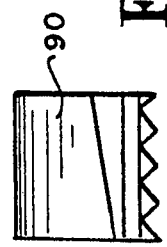

FIG. 5

FIG. 6

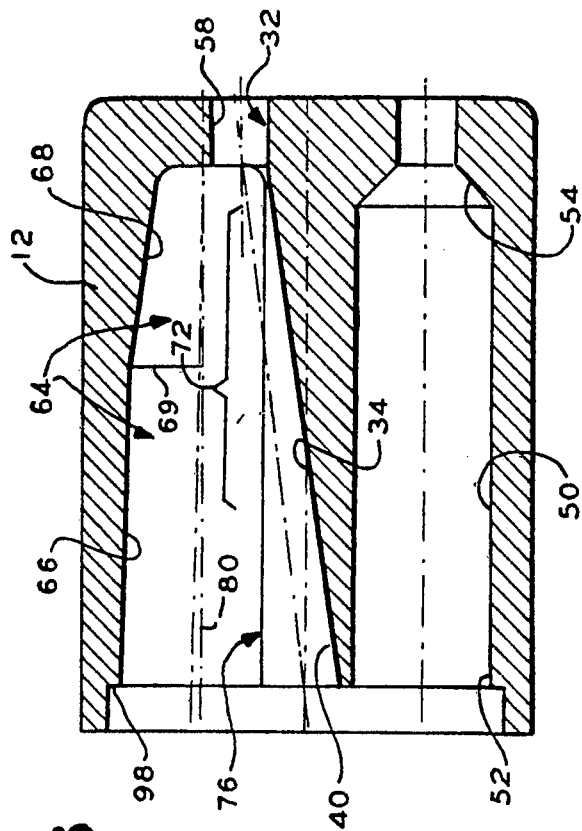
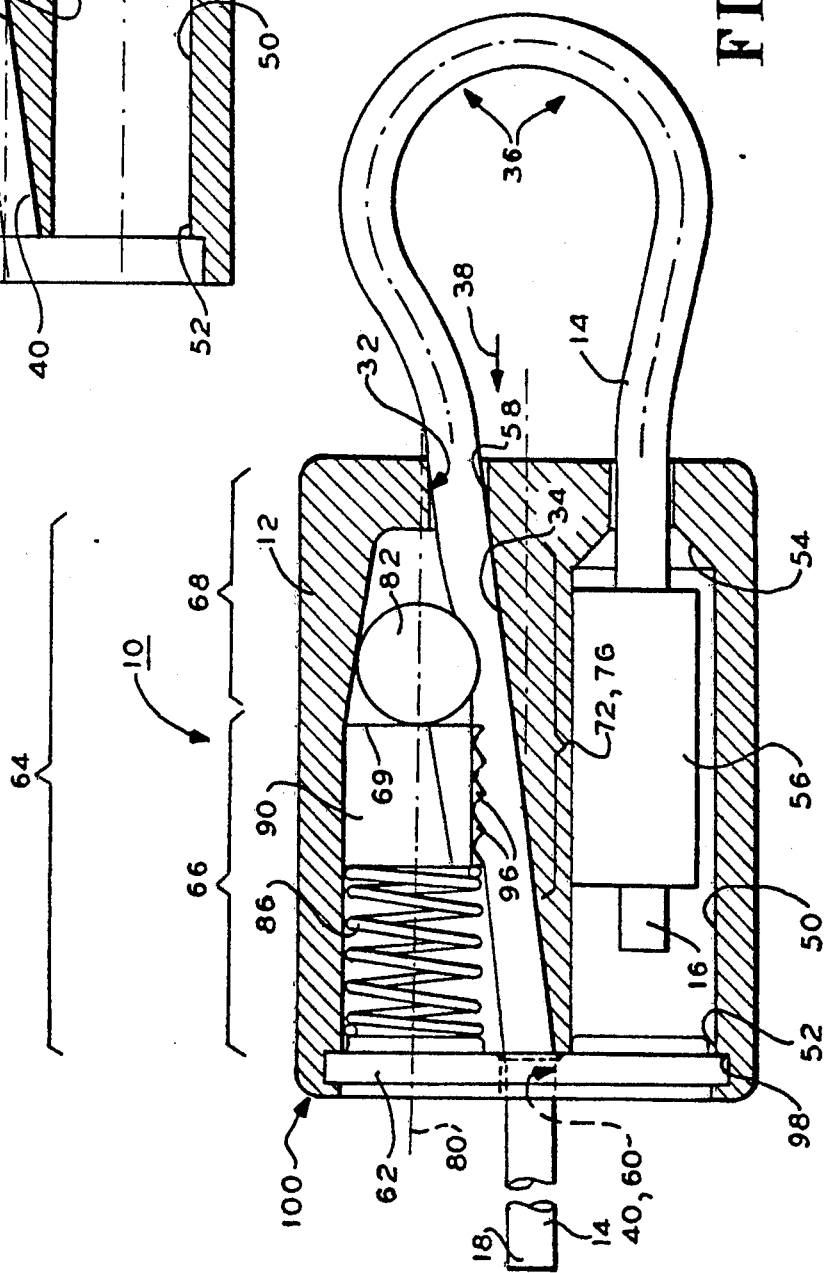

FIG. 3



SECURITY SEAL AND LOCK

BACKGROUND OF THE INVENTION

The present invention relates to an improved security seal and lock and, more particularly, to an improved security seal and lock of the type which includes a robust housing, usually, but not necessarily, made of metal, and a flexible metal cable, one end of which is permanently held in the housing and the other end of which is selectively insertable into and through the housing in a first direction but is not removable in a reverse direction from the housing once so inserted.

Housing-and-cable devices for sealing and locking lockable element such as hasp on a door are known. See for example British Patent 1880 (Issue Jan. 23, 1913) and the following U.S. Pat. Nos. 3,994,521 to Van Gompel; 4,049,303 to Irwin, et al.; 3,770,307 to Van Gompel; 4,747,631 to Loynes, et al.; 5,092,641 to Penick; and 4,216,568 to Anderson, which patent is not, strictly speaking, a patent relating to a security seal and lock but which describes a metal-wire-tensioning apparatus which is constructed and which operates similarly to the seals/locks of the foregoing patents.

Typically, housing-and-cable seals and locks may be used to immobilize the door hasp of shipping vehicles such as railroad boxcars and semi-trailers. Such use provides a method of rendering difficult unauthorized access to goods and materials contained within the boxcars in the semi-trailers. In the event that unauthorized entry does occur as a result of breaking or disintegrating the seal and lock, a visual indication of such unauthorized entry is provided.

It has been, and continues to be, a goal of suppliers of security seals and locks of the housing-and-cable type to provide a seal and lock which is simple in construction, which can be emplaced on the vehicle or container to be safeguarded without the use of special tools, and which cannot be removed unless substantial effort is expended to destroy the device.

In typical prior art security seals and locks of the housing-and-seal type under discussion, one end of a metal cable is more or less permanently affixed to, or more preferably, mounted within, a metal housing. The housing includes a path or passage therethrough along which the other end of the cable may be inserted into, through and out of the housing. The passage or path intersects a cavity within the housing. The cavity may be, in part, defined by a wall or surface which slopes away from the point of entry of the cable into the housing. The cavity may also be slightly skewed relative to the passage way so that a wall thereof slopes away from the point of entry of the cable into the housing.

A ball or disk is located within the cavity. The ball or disk simultaneously engages both the sloping cavity wall and the cable after its insertion. Typically a biasing member such as a spring urges the ball or disk toward the point of entry of the cable into the housing.

Entry of the cable into and through the housing and along the path causes the cable to engage the ball or disk and to move the ball or disk against the action of the biasing member away from the point of entry of the cable into the housing. In actual use, the insertion of the cable into the housing occurs after the cable has been passed through appropriate holes or openings in a hasp or other lockable element of a door or closure on a boxcar, trailer or other vehicle or container so that the

now looped cable immobilizes the hasp or other lockable member.

An attempt to withdraw the cable from the housing by moving it in a reverse direction causes the cable to frictionally engage the ball or disk moving it in the direction of the point entry of the cable. At the same time, the biasing member also acts to move the ball or disk in this same direction. Ultimately, after a small amount of movement of the ball or disk toward the point of entry of the cable, the ball or disk becomes jammed between the cable and the narrowing space defined by the sloped wall of the cavity. Ultimately, this jamming effect becomes so great as to render quite difficult, if not prevent, removal of the cable from the housing without breaking the housing or cutting the cable.

Where a ball is used, it has been found that there is some possibility of withdrawing the cable from the housing if a pulling force and a twisting force are simultaneously applied to the cable. This is apparently due to the fact that twisting causes the ball to roll; such rolling to some extent ameliorates or avoids the jamming of the ball into the cable so that sufficient force to prevent the cable's withdrawal is not applied.

Accordingly, one object of the present invention is the provision of a housing-and-cable lock and seal which is simple in construction, which can be emplaced without the use of special tools which cannot be removed without destruction of the device and which obviates defeat by simultaneous twisting and pulling of the cable.

SUMMARY OF THE INVENTION

With the above and other objects in view, the present invention comprises an improved security seal and lock. The security seal and lock is of the type which includes a flexible metal cable. A first end of the cable is held or permanently mounted in a robust housing. A second opposed end of the cable is selectively insertable through a lockable assembly, such as a hasp or the like, and is then insertable into a first end and out of a second end of a path or passage through the housing. In this way, the lockable assembly is sealed and locked by the resulting cable loop.

Within the housing is a one-way facility which includes a generally cylindrical cavity which extends generally along and is intercepted by the path or passage. The zone of intersection of the path or passage and the cavity constitutes a chamber, the transverse dimension of which decreases in the direction of the first path or passage end and increases in the direction of the second path or passage end. The one-way facility also includes a ball in the chamber which is biased by a biasing facility, for example a spring, toward the first path passage end.

Insertion of the second cable end into the first path or passage end causes the cable to engage the ball and move the ball against the bias of the spring and away from the first path passage end to permit the second cable end to move through the path or passage and out of its second end. An attempt to reversely move the cable causes the bias of the spring and the drag force of the cable on the ball to conjointly move the ball toward the first passage end. This jams the ball against the chamber and the cable in the portion of the chamber having the decreased transverse dimension thereby preventing withdrawal of the cable.

In the type of seal and lock described above, withdrawal of the cable may at times be achieved by simultaneously pulling on the cable and twisting it. The improvement of the present invention prevents this withdrawal. Specifically, in its broadest aspects, the improvement comprises a facility which is located between the spring and the ball. This facility is responsive to twisting of the cable incident to an attempt to withdraw the cable from the passage for increasing the jamming force on the cable.

In one preferred embodiment, the increasing facility may constitute a larger ball in the cavity located between the first ball and the spring. The larger ball may be made of a relatively soft material such as aluminum. Insertion of the cable into the housing is achieved as described above. If an attempt to withdraw the cable involves both a pulling force on the cable and twisting of the cable, the cable pulls the larger ball against the smaller ball to amplify the jamming force of the smaller ball on the cable. This occurs as the larger ball is pulled into the portion of the chamber housing the decreased transverse dimension. If the larger ball is made of a relatively soft material, the twisting cable will dig into the second larger ball, thereby increasing the frictional drag exerted on the larger ball by the cable as pulling is effected. In this manner, the larger ball is (i) positively pulled with the cable to exert a jamming force between the portion of the chamber which has the decreased transverse dimension and the cable and (ii) is also positively pulled against the smaller ball to amplify and increase its jamming force on the cable.

In a second preferred embodiment, the increasing facility is a generally cylindrical member having serrations formed around a portion of its circumference which is located within the chamber so that its major axis is generally along the chamber. The cylindrical member is located so that its serrations face the cable path or passage. Again, insertion of the cable is achieved as set forth above. If an attempt to withdraw the cable is accompanied by both pulling and twisting, the serrations on the cylindrical member dig into the cable and the cylindrical member becomes jammed against the cable and the portion of the chamber having the decreased transverse dimension. Additionally, the movement of the cylindrical member toward the point of insertion of the cable causes it to abut the ball and to move the ball toward the point of insertion so that the ball jams even harder against the chamber and the cable.

BRIEF DESCRIPTION OF THE DRAWING

FIG. 1 is a front elevation of a security seal and lock according to the present invention with the seal and lock in place to immobilize hasps mounted to otherwise relatively moveable members for sealing and locking thereof;

FIG. 2 is a sectional view of the security seal and lock of FIG. 1 which shows the internal structure thereof according to a first embodiment of the present invention;

FIG. 3 is similar to FIG. 2 and depicts a second embodiment of the present invention;

FIGS. 4 and 5 constitute respectively an end view and front elevation of an element of the security seal and lock depicted in FIG. 3; and

FIG. 6 is a sectioned elevation of a housing used in the security seal and lock of FIGS. 1-3.

DETAILED DESCRIPTION

A security seal and lock 10 according to the present invention includes a housing 12 and a cable 14. The housing 12 may be made of any robust material such as cast zinc (ZAMAK #3), which may be chromated to provide resistance to environmental degradation, or nylon, 30% of the volume of which is filled with glass fibers. The housing 12 may be made of any other material which is robust and is more or less resistant to being easily broken or rendered disintegral. The cable is preferably flexible cable such as 16 or 3/32 aircraft cable, 7×7 galvanized steel (MIL-W-83420B).

The cable 14 has a first end 16 (not visible in FIG. 1) which is held, or is more or less permanently mounted within, the housing 12. A second end 18 of the cable 14 is normally free.

In use, the second end of 18 of the cable 14 is first inserted through holes or openings 20, 22 formed through hasps 24, 26 which are mounted to or are formed integrally with two moveable members 28, 30 such as a door and a door jam, two doors, etc. Obviously, one or more of the hasps 24, 26 could be configured as the staple of a staple/hasp door-locking arrangement.

After the second end 18 of the cable 14 is passed through the holes 20 and 22, it is inserted at the first end 32 of a path or passage 34 (not visible in FIG. 1) formed through the housing 12. Such insertion forms the cable 14 into a loop 36 where it passes through the holes 20 and 22. As shown by the directional arrow 38, following initial insertion of the second end 18 of the cable 14 into the first end 32 of the path or passage 34, such second end 18 and the cable 14 itself are moved through the path or passage 34 until the second cable end 18 exists the housing 12 from a second end 40 of the path or passage 34.

As is known in the prior art, the housing 12 preferably includes a one-way facility 42 (not visible in FIG. 1) which permits the cable 14 to be moved through the passage 34 in the direction of the arrow 38, but which prevents the cable 14 from being withdrawn from the path or passage 34 in the direction of the arrow 44.

The presence of the cable loop 36 in the holes 20 and 22 immobilizes the hasps 24 and 26 and the moveable members 28 and 30, thereby sealing and locking the members 28 and 30 to secure the contents of any container or vehicle of which they form a part and which contains goods or merchandise.

Referring now to FIG. 2, there is shown a first preferred embodiment of the present invention. As may be seen, the housing 12 includes a bore 50 which is opened at one end 52 and which narrows at its other end 54 so as to ultimately have a diameter only slightly larger than the diameter of the cable 14. The first end 16 of the cable 14 is located within the bore 50. Attached to this first end 16 is a ferrule 56 which is attached to the cable 14 in any convenient fashion. The ferrule 56 has a diameter substantially larger than the narrow end 54 of the bore 50, thus preventing withdrawal of the first cable end 16 from the bore 50. In this or a functionally equivalent manner, the first end 16 of the cable 14 is held in, and more or less permanently mounted to, the housing 12.

Referring to FIGS. 2 and 6, the path or passage 34 may be seen to extend between the first end 32 and the second end 40 thereof. The first end 32 of the path or passage 34 constitutes a hole 58 formed through the

housing 12. As described in greater detail below, the second end 40 of the passage 34 may constitute a hole 60 formed through a closure plate or plug 62 which is mounted to the housing 12 so as to close the bore 50 and a cavity 64 also formed in the housing 12.

The cavity 64 has a generally cylindrical portion 66 extending from the vicinity of the second end 40 of the path or passage 34 toward the first end 32 of the path or passage 34, and a conical portion 68, the diameter or transverse dimension of which decreases from its intersection (at 69) with the cylindrical portion 66 in the direction of the first end 32 of the path or passage 34. The path or passage 34 intersects the cavity 64 along a zone of intersection 72. Along this zone of intersection 72 the path or passage 34 and the cavity 64 may be viewed as together constituting a chamber 76. Preferably, as shown in the Figures, the path or passage 34 is slightly skewed or angularly related to the major or longitudinal axis 80 of the cavity 64. As a consequence, the transverse dimension of the chamber 76 decreases in the direction of the first end 32 of the path or passage 34. This diametric decrease is due to both the diametric decrease of the conical portion 68 and to the angular relationship of the path or passage 34 relative to the cavity 64.

Within the chamber 76 there are located a first ball 82 and a second ball 84. Acting between the closure plate 62 and the second ball 84 is a resilient or biasing member 86 such as a coil spring or a functionally equivalent element.

Ignoring for the time being the second ball 84 and assuming that the resilient member 86 acts directly against the first ball 82, the operation of prior art devices will be described.

Upon insertion of the second end 18 of the cable 14 into the first end 32 of the path or passage 34, and following additional insertion of the cable 14, such cable 14 contacts the periphery of the first ball 82. Movement of the cable 14 frictionally carries or drags the ball 82 leftwardly in FIG. 2 against the force of the resilient member 86 into the larger diametric portion of the chamber 76 defined by the cylindrical portion 66. Continued movement of the cable 14 along and through the path or passage 34 continues until the second end 18 of the cable 14 exits the second end 40 of the path or passage 34. The foregoing movement of the cable 14 is in the direction of the arrow 38. If a pulling force is now applied to the cable 14 in the direction of the arrow 44, both the frictional drag of the cable 14 on the first ball 82 and the force of the resilient member 86 urge and move the first ball 82 farther and farther into the diametrically decreasing portion of the chamber 76 defined by the conical portion 68. At some point the first ball 82 is jammed with great force against the wall of the conical portion 68 and the cable 14. The jamming of the first ball 82 against the cable 14 jams the cable 14 against the wall of the path or passage 34. In theory, this jamming prevents the cable 14 from being withdrawn from the housing 12.

While the foregoing structure operates reasonably well, it has been found that there is, in some circumstances, a possibility that applying both a pulling and a twisting force to the cable 14 can permit defeat of the seal and lock 10. Specifically, where only the first ball 82 is present, appropriate twisting of the cable 14 while a pulling force is judiciously applied to the cable 14, causes the first ball 82 to roll tangentially to the cable 14

and permits the cable 14 to be "eased out" of the path or passage 34 and its first end 32.

Accordingly, the present invention constitutes facilities responsive to twisting of the cable 14 for increasing the jamming force on the cable 14 to prevent its withdrawal from the housing 12.

In FIG. 2, the jamming force-increasing facility constitutes the second ball 84. In all preferred embodiments of the present invention the first ball 82 is made of stainless steel and is relatively hard. This leads to durability and the ability of the ball 82 to forcefully jam the cable 14. The hardness of the first ball 82, however, also probably contributes to the ability to withdraw the cable 14 from the housing 12 by twisting the cable 14 as described above. In the present embodiment, the second, larger ball 84 may be made of aluminum.

As shown in FIG. 2, the second ball 84 is located in the chamber 76 along with the first ball 82 and is positioned between the resilient member 86 and the first ball 82. Because of its location in a somewhat enlarged diametric portion of the chamber 76, the second ball 84 has a larger diameter than the first ball 82. The second ball 84 may also be softer than the first ball 82 for a purpose described immediately below.

As shown in FIG. 2, with the cable 14 fully inserted, an attempt to withdraw the cable 14 results in the first ball 82 jamming between the conical portion 68 of the cavity 64 and the cable 14 and the second ball 84 jamming between the cylindrical portion 66 of the cavity 64 and the cable 14. Thus when only a pulling force is applied to the cable 14, the seal and lock 10 of the present invention performs similarly to the seals and locks of the prior art.

Assuming now that both a twisting force and a pulling force are applied to the cable 14, while twisting may tend to cause the harder first ball 82 to rotate within the chamber 76, the pulling force applies to the larger diameter second ball 84 is sufficient to move the second ball 84 against the first ball 82. This has the effects of inhibiting rotation of the first ball 82 and of jamming the first ball 82 even more firmly against the cable 14 and into the portion of the chamber 76 having the decreased transverse or diametric dimension. Both effects amplify the jamming force of the first ball 82 on the cable 14.

Where, as preferred, the second ball 84 is softer than the first ball, as when it is made of aluminum, the cable 14 will dig into the softer second ball 84, ultimately positively preventing the second ball 84 from rotating within the chamber 76. The cable 14 being now dug into the second ball 84, positively pulls the second ball 84 rightwardly as viewed in FIG. 2. Rightward movement of the second ball 84 further jams this ball 84 against the walls of the cylindrical portion 66 of the cavity 64 and the cable 14; it also urges the second ball 84 against the first ball 82. This latter action moves the first ball 82 further into the diametrically decreasing conical portion 68 increasing the jamming force of the first 82 on the cable 14. Thus removal of the cable 14 by twisting and pulling the cable 14 is prevented by the force-increasing function of the second ball 84.

A second preferred embodiment of the present invention 10 is shown in FIG. 3. Like reference numbers are used for elements which are like or similar to those shown in FIG. 2.

In FIG. 3, the second ball 84 is replaced by a generally cylindrical member 90, shown in greater detail in FIGS. 4 and 5. The member 90 may be made of zinc (ZAMAK III) and comprises a semi-circular peripheral

portion 92 and a serrated non-circular peripheral portion 94. The member 90 is located in the chamber 76 so that the major axis thereof generally aligns with the axis of the coil spring 86 and the first ball 82. Further, the member 90 is located in the chamber 76 so that the serrations 96 face the path or passage 34. An attempt to remove the cable 14 from the seal and lock 10 of FIG. 3 by applying both twisting and pulling force to the cable 14 causes the serrations 96 of the member 90 to dig into the cable 14 until the member 90 cannot rotate within the chamber 76. The non-circularity of the member 90 may be such as to positively present its rotation within the cylindrical portion 66 of the cavity 64. The foregoing results as the member 90 is moved rightwardly in FIG. 3 and is jammed more and more against the walls of the generally cylindrical portion 66 of the cavity 64 and the cable 14. As with the embodiment of FIG. 2, the member 90 also abuts the first ball 82 increasing the jamming force of the first ball 82 against the walls of the conical portion 68 of the cavity 64 and the cable 14. Again, twisting of the cable 14 does not avail an unauthorized attempt to remove the cable from the housing 12.

As noted earlier, the closure plate 62 may close the bore 50 and the cavity 64. Preferably, the hole 60 in the closure plate 62 is located on a axis of symmetry of the plate 62 so that the plate 62 may be located in the position shown or in a position which is rotated 180° into and out of the plane of the Figures. The closure plate 62 may be mounted to the housing 12 by fitting it into the end of the housing 12 and against a circumferential lip 98 so that it resides below the level of the end of the housing 12 and then rolling over the material of the housing 12 as shown at 100 to retain the plate 62. Other equivalent assemblies, such as where the housing is made of a robust non-metal, may of course be utilized.

While the foregoing describes preferred embodiments of the present invention, those having ordinary skill in the art will appreciate that numerous other arrangements may be utilized which fall within the spirit and scope of the following claims.

What is claimed is:

1. A security seal and lock for a lockable assembly, which comprises:
 - a robust housing having a path with a first end and a second end formed therethrough, the housing also having a generally cylindrical cavity which extends generally along and intersects the path, the zone of intersection of the path and the cavity constituting a chamber, the transverse dimension of the chamber decreasing in the direction of the first path end;
 - a flexible metal cable, a first end of which is held in the housing and a second end of which is selectively insertable through the lockable assembly and then through the first path end and out of the second path end so that the lockable assembly is sealed and locked by the resulting cable loop;
 - a ball in the chamber;
 - means in the chamber for biasing the ball toward the first path end, insertion of the second cable end into the first path end causing the cable to engage the ball and to move the ball against the action of the biasing means and away from the first path end to permit the second cable end to move along the path and out of the second path end, an attempt to reversely move the cable causing the action of the biasing means and the force of the cable on the ball

to move the ball toward the first path end thereby jamming the ball against the wall of the chamber and the cable to prevent withdrawal of the cable; and

- means located between the biasing means and the ball and responsive to twisting of the cable incident to an attempt to withdraw the cable from the passage for increasing the jamming force on the cable.
2. A security seal and lock as set forth in claim 1, wherein:
 - the increasing means comprises a second ball larger than the first ball and located between the biasing means and the first ball in the chamber.
3. A security sealed lock as set forth in claim 2, wherein:
 - the second ball being made of a material which is sufficiently soft so that a twisting force on the cable which accompanies a pulling force on the cable causes the cable to dig into the second ball and to forcefully pull the second ball toward the first path end and into engagement with the first ball so that the second ball jams against the wall of the chamber and the cable and increases the jamming force exerted by the first ball on the cable.
4. A seal and lock, set forth in claim 2, wherein:
 - the biasing means comprises a spring acting between the housing near the second path end and the second ball.
5. A seal and lock, as set forth in claim 4, which further comprises:
 - a bore formed in the housing adjacent to the path and the cavity;
 - a ferrule mounted to the first end of the cable and located within the bore, the ferrule preventing movement of the first cable and out of the bore.
6. A security seal and lock, as set forth in claim 5, wherein the housing includes:
 - a plate having a central hole therethrough, the spring action against the plate; and
 - means on the housing for retaining the plate attached thereto so that the bore and the cavity are closed thereby and the hole is aligned with the second end of the path.
7. A security seal and lock, as set forth in claim 6, wherein:
 - the second end of the path is equidistantly located between the cavity and the bore so that either portion of the plate on either side of the hole is capable of closing the cavity or the bore.
8. A security seal and lock, as set forth in claim 1, wherein:
 - the increasing means comprises a generally cylindrical member located between the biasing means and the ball and having a serrated surface facing the path, a twisting force on the cable which accompanies a pulling force causing the serrations to dig into the cable so that the member is pulled by the cable toward the first path end causing the member to jam against the cable and the wall of the chamber and moving the member against the ball to increase the jamming action thereof.
9. A security seal and lock as in claim 8, wherein:
 - the cylindrical member is so shaped as to be unable to rotate within the chamber about its axis generally parallel to the cable.
10. A security seal and lock as in claim 9, wherein:

9

the biasing means comprises a spring acting between the housing near the second path end and the cylindrical member.

11. A security seal and lock as in claim 10, wherein the housing includes:

a plate having a central hole therethrough, the spring acting against the plate; and

means on the housing for retaining the plate attached thereto so that the bore and the cavity are closed thereby and the hole is aligned with the second end of the path.

12. An improved security seal and lock of the type which includes (a) a flexible metal cable, a first end of which is held in a metal housing and a second end of which is selectively insertable through a lockable assembly and then through a first end and out of a second end of a path through the housing so that the assembly is sealed and locked by the resulting cable loop and (b) a one-way facility within the housing, the facility including a generally cylindrical cavity which extends

10

generally along and is intersected by the path so that the path and the cavity constitute a chamber, the transverse dimension of which chamber decreases in the direction of the first path end, and a ball in the chamber which is biased by a spring member toward the first path end; insertion of the second cable end into the first path end causing the cable to engage the ball and move the ball against the bias and away from the first path end to permit the second cable end to move along the path and out of its second end, an attempt to reversely move the cable causing the bias and the drag force of the cable on the ball to move the ball toward the first path end thereby jamming the ball against the chamber and the cable to prevent withdrawal of the cable; wherein the improvement comprises:

means located between the spring member and the ball and responsive to twisting of the cable incident to an attempt to withdraw the cable from the passage for increasing the jamming force on the cable.

* * * * *

25

30

35

40

45

50

55

60

65